

FOCUS

RAVEN MAX - LINER ASSEMBLY

R.A.T. thru-axles are sold under licence in the UK (UK patent GB2414971B)

ASSEMBLY PARTS

FRAME WITH FRONT DERAILLEUR ADAPTER OPTION (2x, 3x version)

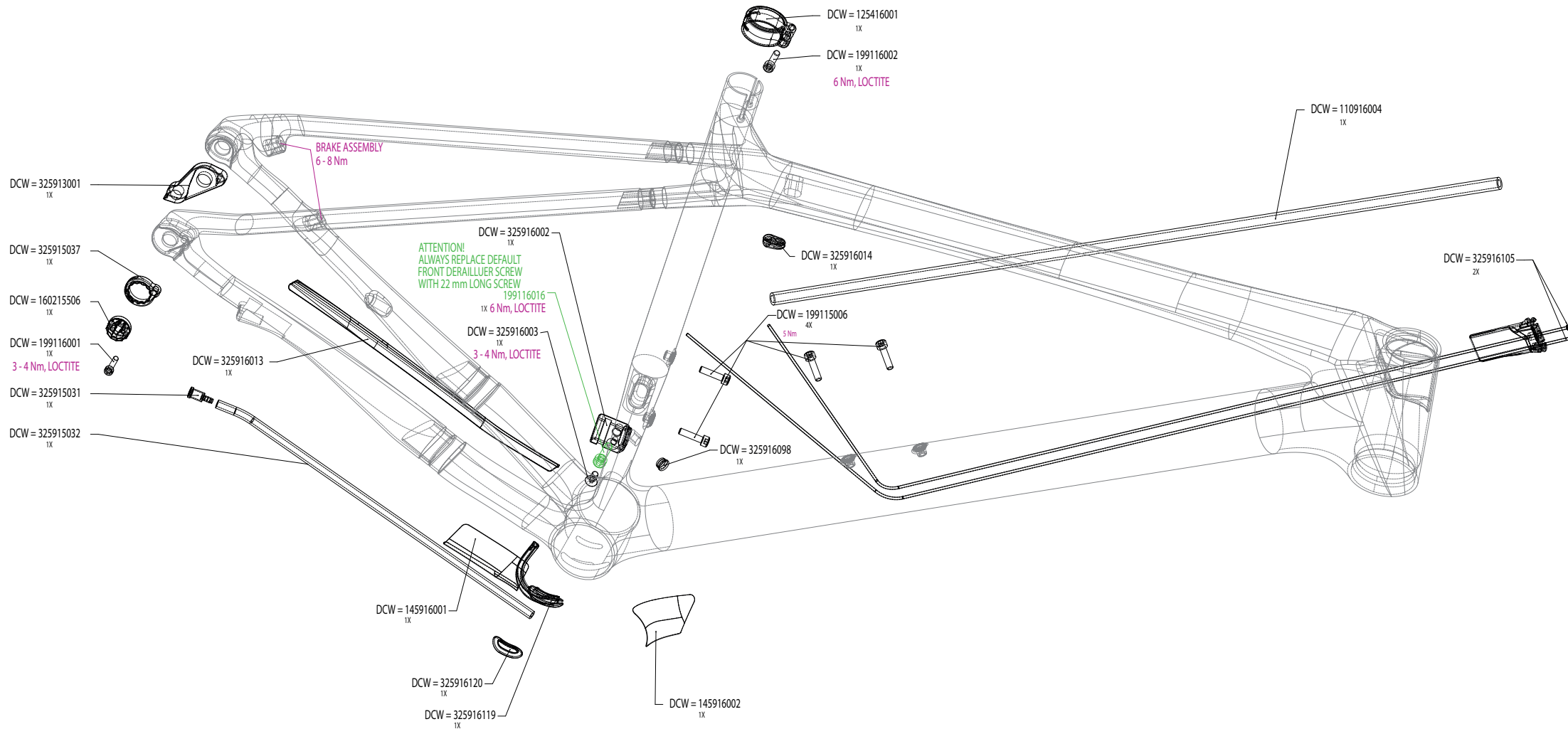

ASSEMBLY PARTS

FRAME WITHOUT FRONT DERAILLEUR ADAPTER OPTION (1x version)

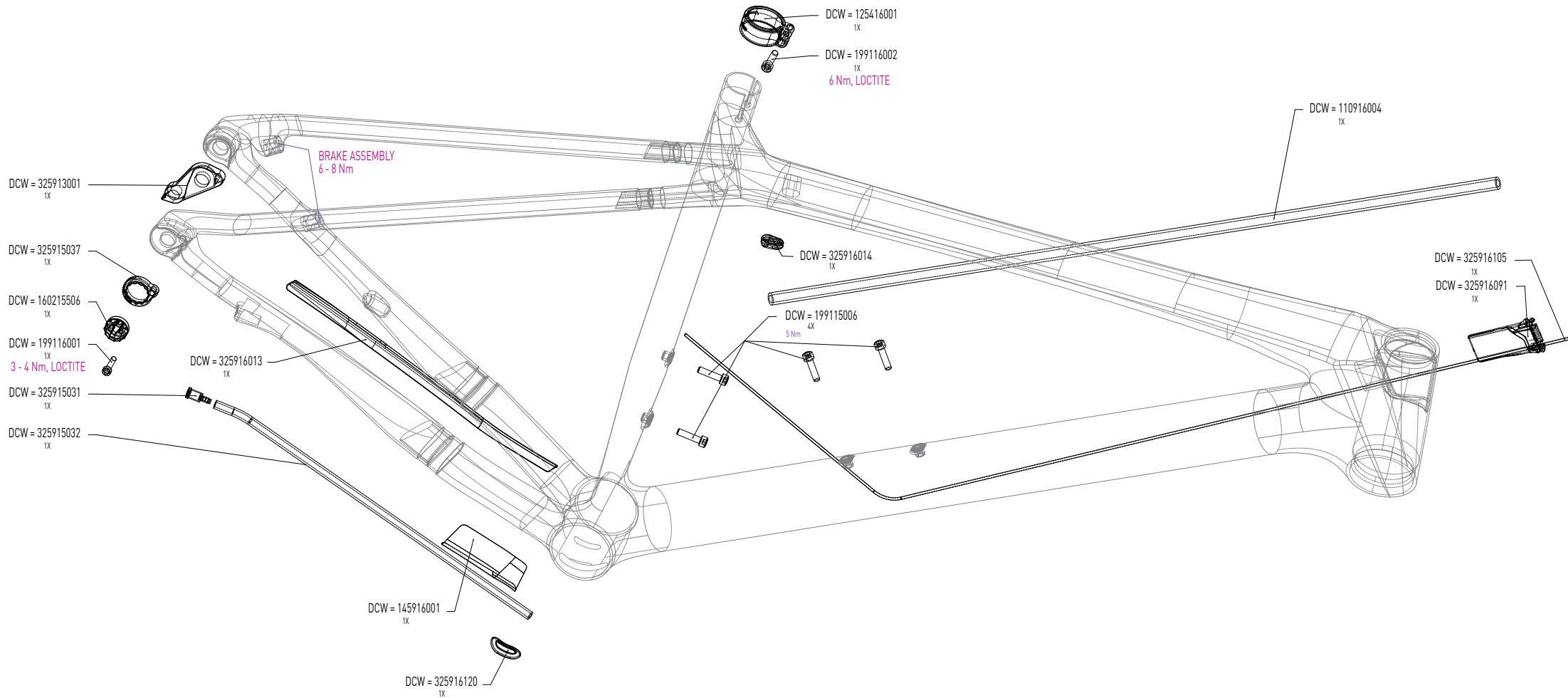

RAVEN MAX - LINER ASSEMBLY

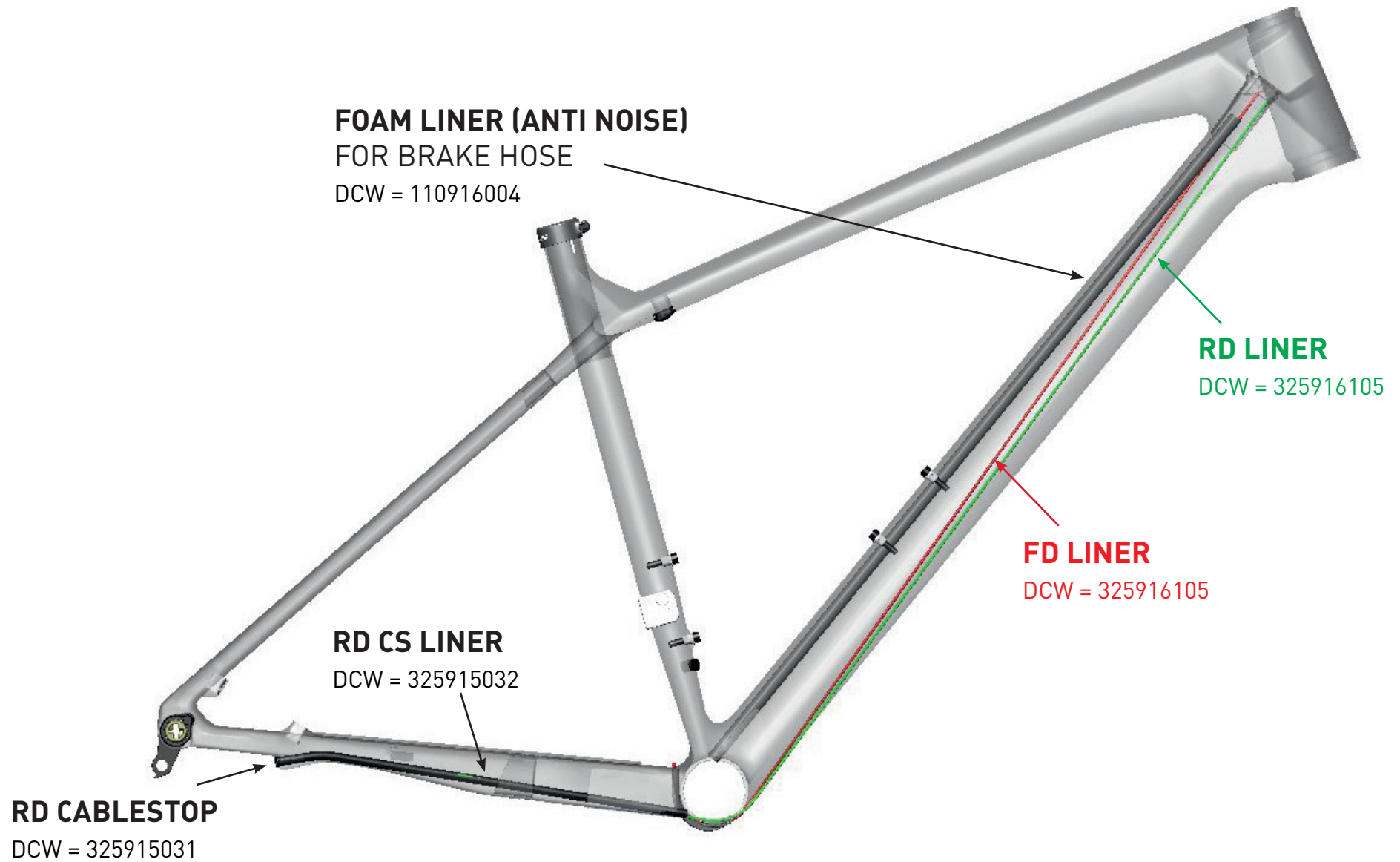

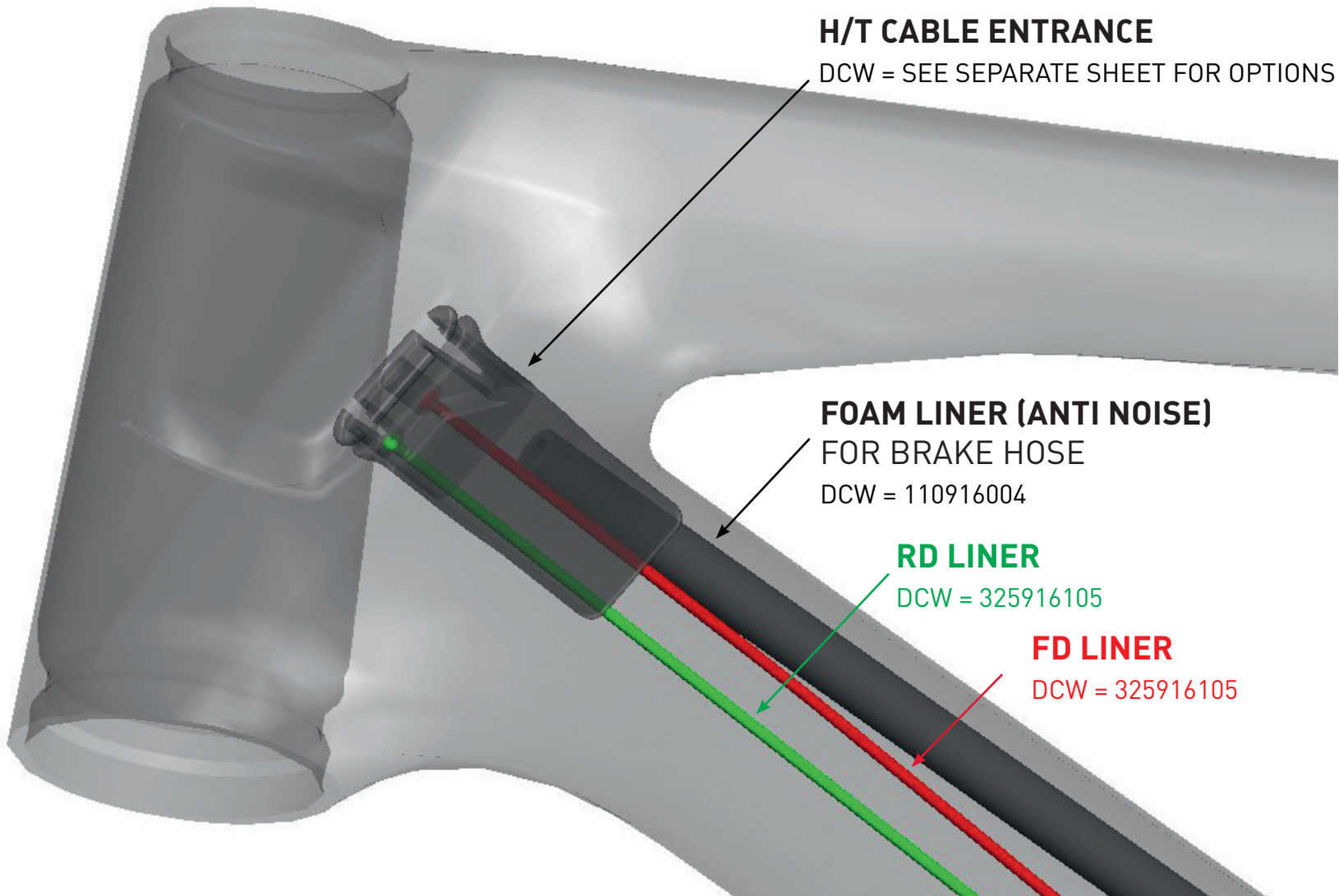

H/T CABLE ENTRANCE

DCW = SEE SEPARATE SHEET FOR OPTIONS

FOAM LINER (ANTI NOISE)

FOR BRAKE HOSE

DCW = 110916004

RD LINER

DCW = 325916105

FD LINER

DCW = 325916105

NOTE TRUMPET SHAPE OF LINER!

H/T CABLE ENTRANCE

DCW = SEE SEPARATE SHEET FOR OPTIONS

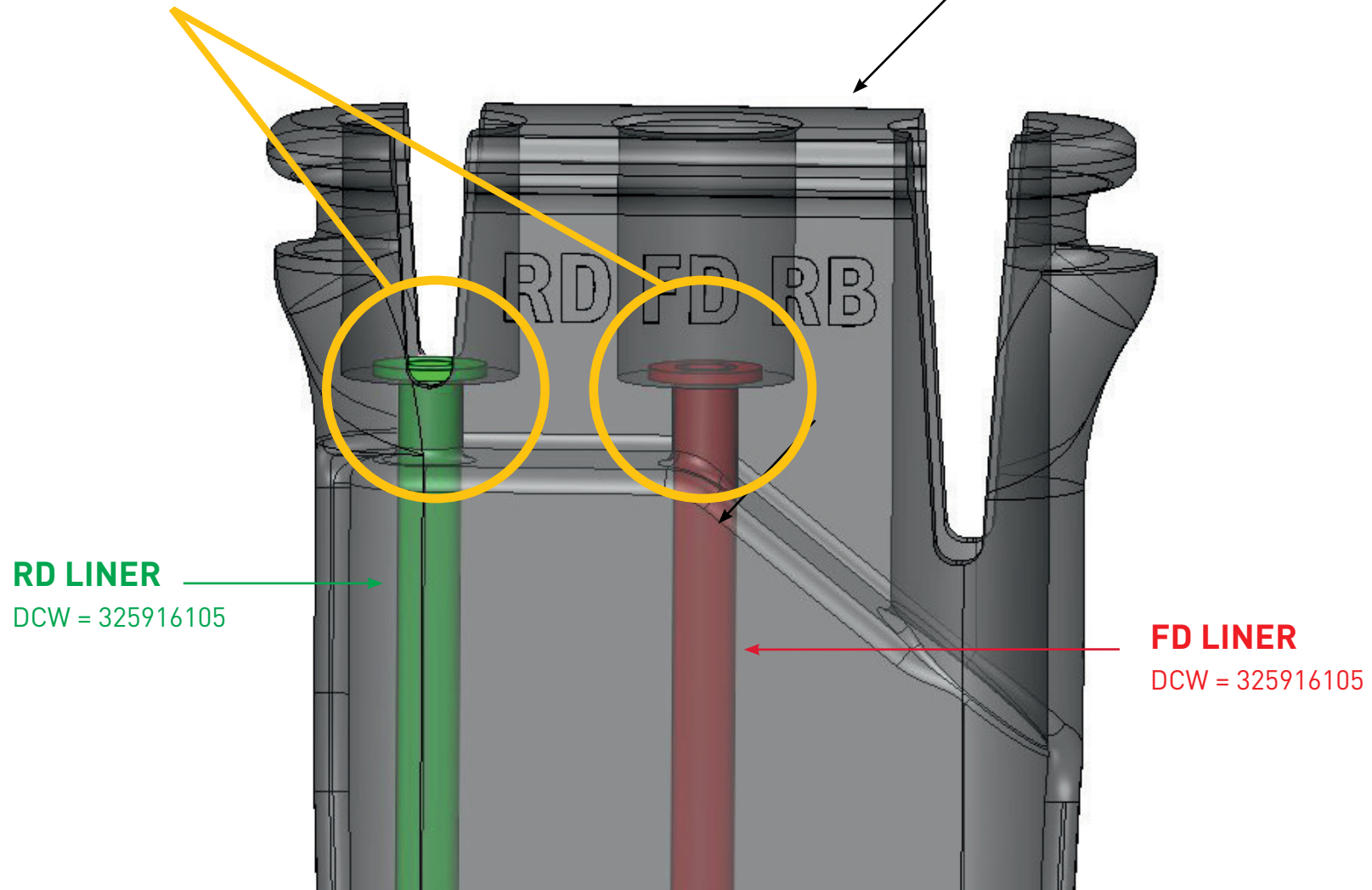

RAVEN MAX - LINER ASSEMBLY

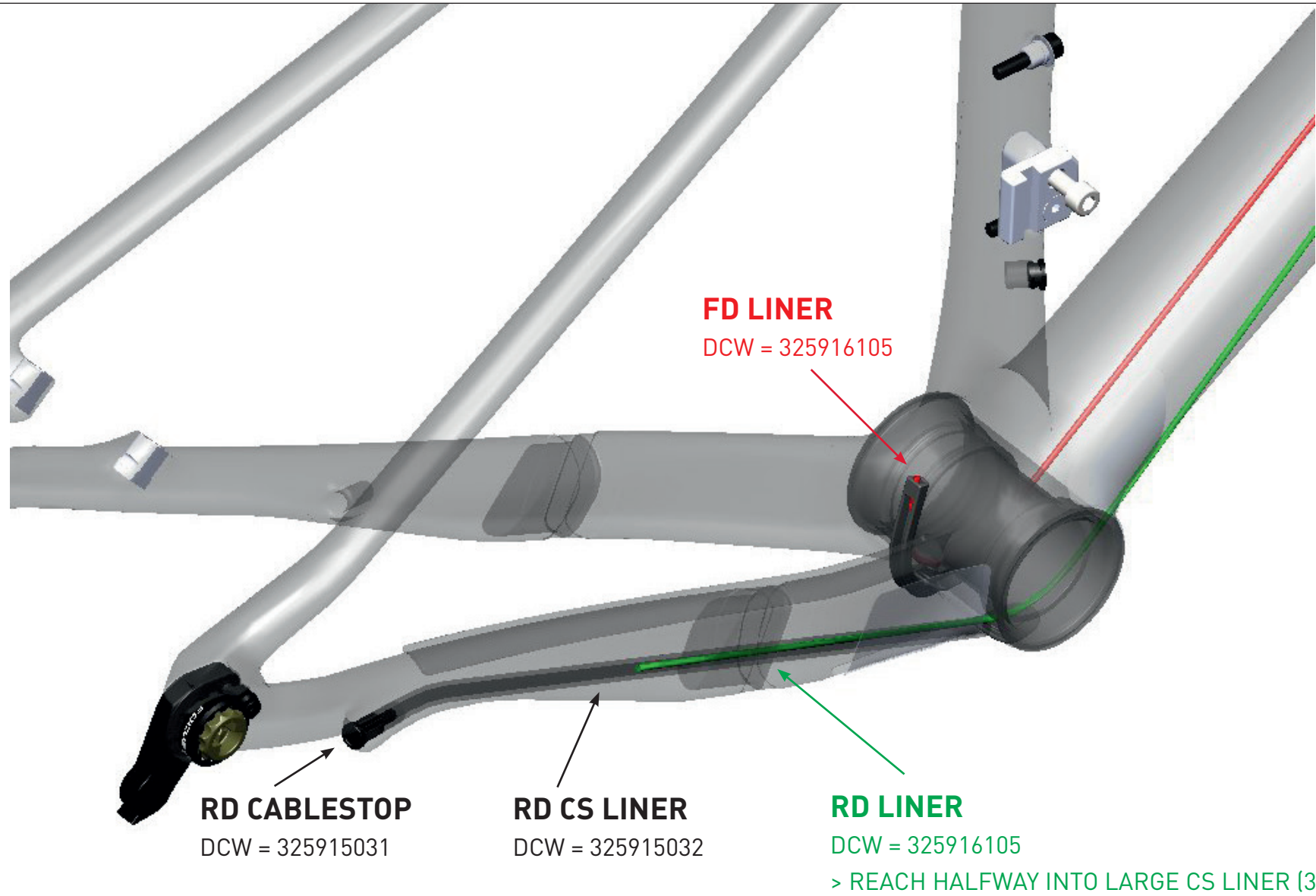

RAVEN MAX: Safety advice bottom bracket sleeve

DANGER!

Always use a proper bottom bracket (B/B) sleeve. Otherwise there is a high risk of serious injury or death. The sleeve should run through the B/B shell from left to right without interruption. The sleeve needs to be made from stiff, strong material (e.g. original SRAM PF30 sleeve or aluminum material) to withstand the RD shift cable's tension. The min. outer diameter of the sleeve needs to be 40 mm, the maximal outer diameter of the sleeve cannot be larger than 44 mm, close to the pressfit zone (8-10 mm width). If a soft sleeve is used, there is high risk of damaging both liner and then soft sleeve and B/B axle (s. fig.).

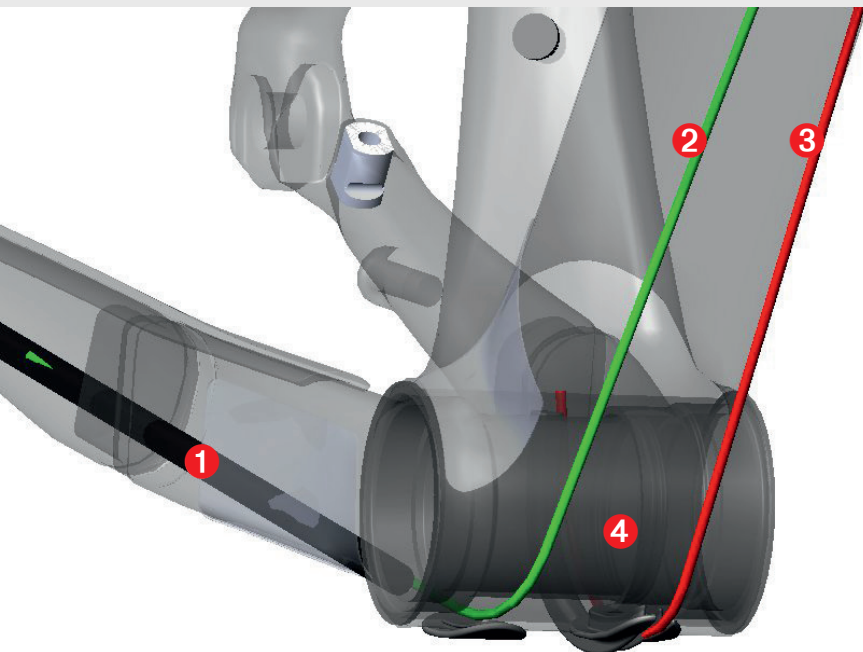

1. RD CS LINER (DCW = 325915032)
2. RD LINER [DCW = 325916105; REACHES HALFWAY INTO RD CS LINER (DCW = 325915032)]
3. FD LINER (DCW = 325916105; ENDS IN FD GUIDE)
4. P30 SLEEVE

H/T CABLE ENTRANCE

Options

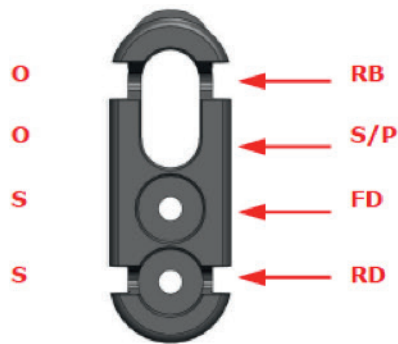

MECHANICAL 2x / 3x
w/ remote S/P routing option
Imprint "4 cables" (current version)

O-O-S-S

DCW = 325916047

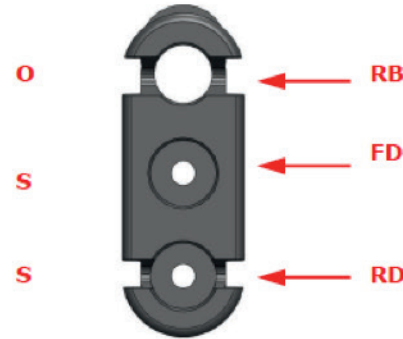

MECHANICAL 2x / 3x
w/o remote S/P routing option
Imprint "RD FD RB"

O-S-S

DCW = 325916089

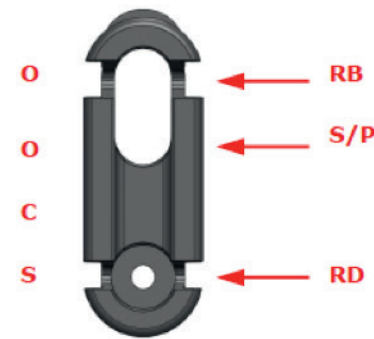

MECHANICAL 1x
w/ remote S/P routing option
Imprint "RD SP RB"

O-O-C-S

DCW = 325916090

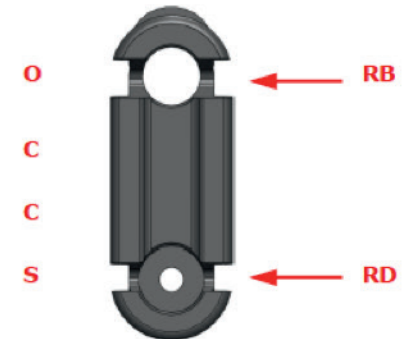

MECHANICAL 1x
w/o remote S/P routing option
Imprint "RD RB"

O-C-C-S

DCW = 325916091

**BRAKE HOSE NEEDS TO RUN
OUTSIDE B/B SLEEVE**



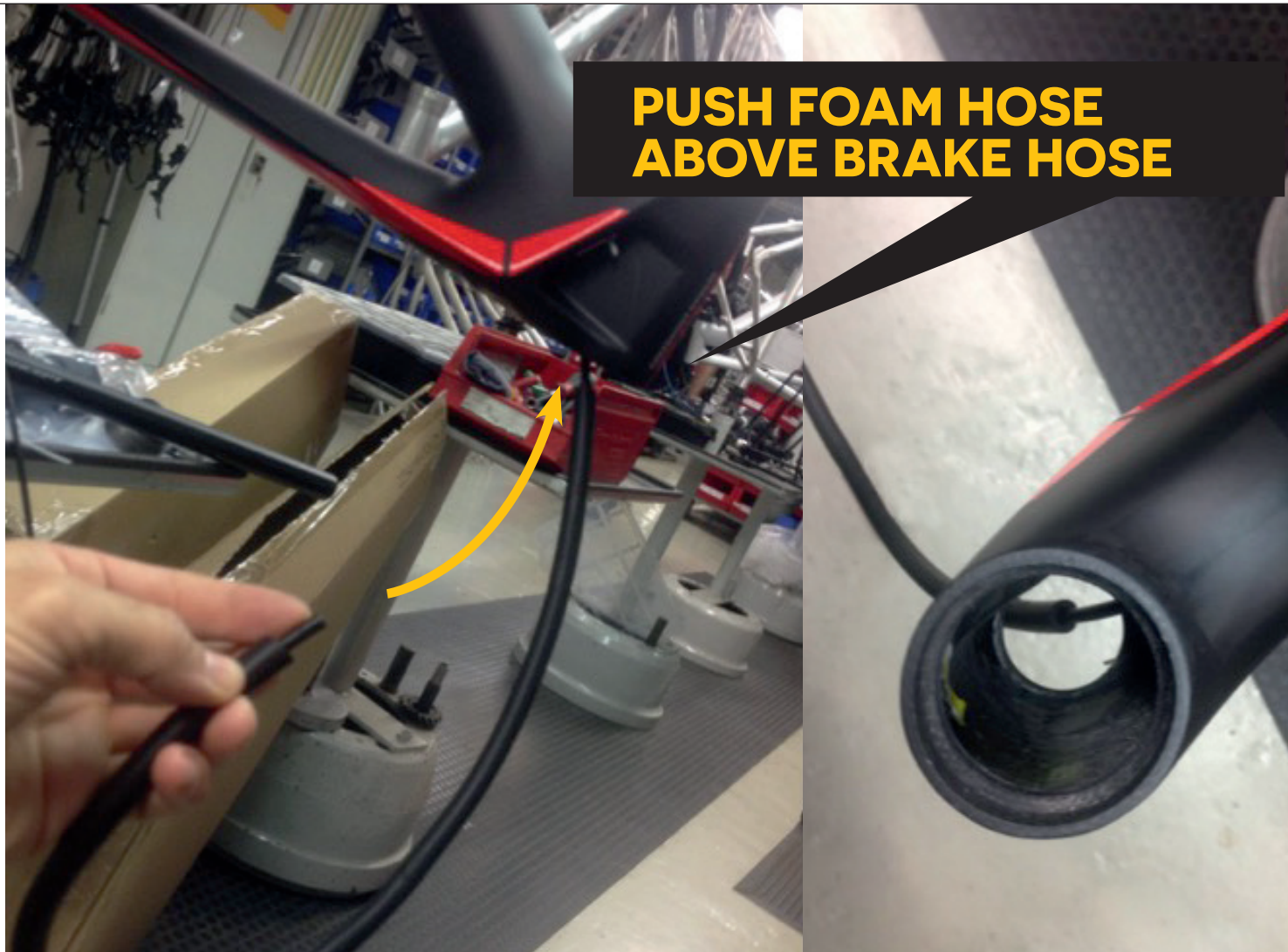

WWW.FOCUS-BIKES.COM